

STATIC DIMENSIONS

Loader end max. payload: 4078lb (1850kg) Max. lift height: 10.59ft (3.23meters)

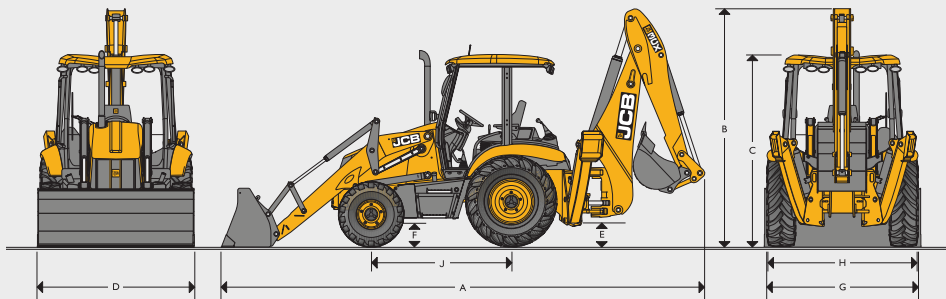

Drive		4WD	
A	Transport length	ft-in (m)	23-7 (7.19)
B	Transport height – standard Backhoe	ft-in (m)	11-3 (3.43)
B	Transport height – Extradig	ft-in (m)	11-7 (3.53)
C	Height to top of cab/canopy	ft-in (m)	9-3 (2.81)
D	Overall width with loader bucket	ft-in (m)	7-8 (2.45)
E	Ground clearance – mainframe	ft-in (m)	1-1 (0.33)
F	Ground clearance – front axle	ft-in (m)	1-1.4 (0.34)
G	Front wheel track	ft-in (m)	7-1 (2.16)
H	Rear wheel track	ft-in (m)	7-3 (2.21)
J	Wheelbase	ft-in (m)	7-1 (2.17)

ENGINE

Manufacturer	JCB		
Aspiration	Turbocharged		
Displacement	liter	4.4	
No. of cylinders	4		
Bore	inch	4.05	
Stroke	inch	5.0	
Rated engine	rpm	2200	
<b>Power ratings</b>			
Gross HP - SAE J1995 (ISO 14396)	hp (kW)	74 (55)	
Net HP - SAE J1349	hp (kW)	71 (53)	
<b>Maximum torque</b>			
Rated ISO 14396 (SAE J1995)	lb ft (Nm)	295 (400)	
Max. Torque	rpm	1200	

EXCAVATOR/LOADER PERFORMANCE

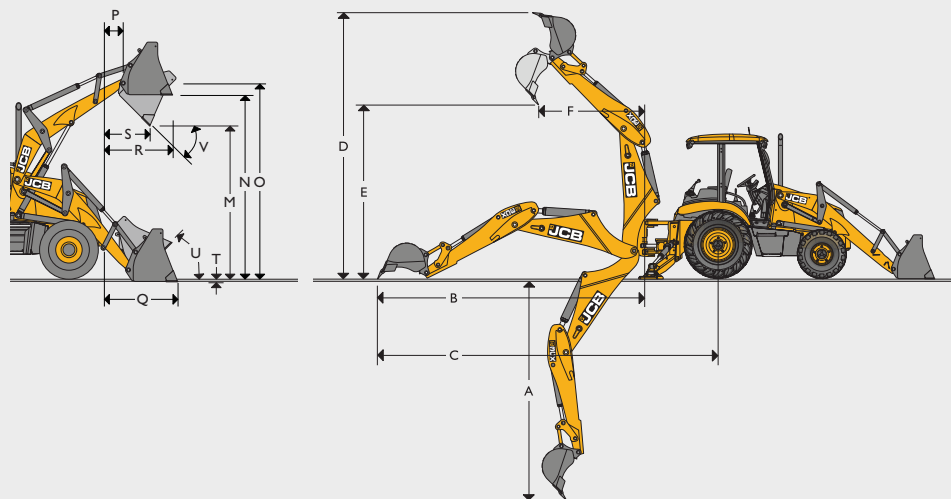

Excavator performance		Fixed dipper	Extending dipper
A	Max dig depth	ft-in (m)	14 (4.24)
B	Reach-ground level to rear wheel center	ft-in (m)	22 (6.72)
C	Reach-ground level to slew center	ft-in (m)	17-6 (5.37)
D	Reach at full height to slew center	ft-in (m)	9 (2.74)
E	Max. working height	ft-in (m)	18 (5.53)
F	Max. load over height	ft-in (m)	12-7 (3.84)
G	Bucket rotation – power	degrees	185°
	Bucket breakout force	lbf (kgf)	13940 (6324)
	Dipper breakout force	lbf (kgf)	7092 (3217)
<b>Loader performance</b>		<b>GP</b>	<b>6-in-1</b>
M	Dump height	ft-in (m)	9 (2.74)
N	Load over height	ft-in (m)	10-6 (3.23)
O	Pin height	ft-in (m)	11-4 (3.45)
P	Pin forward reach	ft-in (m)	1 (0.36)
Q	Reach at ground	ft-in (m)	4-7 (1.42)
R	Max. reach at full height	ft-in (m)	4 (1.20)
S	Reach at full height – bucket dumped	ft-in (m)	2-8 (0.83)
T	Below ground level dig depth	ft-in (m)	0-3 (0.07)
U	Rollback at ground	degrees	45°
V	Dump angle	degrees	43°
	Shovel breakout force	lbf (kgf)	13600 (6170)
	Loader arm breakout force	lbf (kgf)	10900 (4942)
	Shovel capacity	yd <sup>3</sup> (m <sup>3</sup> )	1.1/1.3 (0.88/1.0) (GP shovel) 1.3 (1.0) (6-in-1 shovel)

**SERVICE CAPACITIES**

Cooling system	gal (ltr)	4.2 (18.5)
Fuel tank	gal (ltr)	38 (173)
Engine oil with filter	gal (ltr)	3.4 (15)
Gearbox with filter	gal (ltr)	3.6 (16)
Rear axle	gal (ltr)	3.6 (16)
Front axle	gal (ltr)	3.6 (16)
Hydraulic system incl. tank	gal (ltr)	29.5 (130)
Hydraulic tank	gal (ltr)	22 (85)

**TRANSMISSION**

JCB Synchro-shuttle transmission: It provides superb drive power in all conditions. It consists of a 4-speed, full synchromesh gearbox with integral torque convertor and electrically operated reversing power shuttle.

- Easy-to-use, column mounted electric reversing shuttle which can change machine direction while allowing operator to keep hands on the steering wheel leading to fast cycle times.
- The pedal layout and conventional 4-pattern gear lever with transmission disconnect switch adds to the overall ease of operation. On-the-move gear changes are possible.
- Torque convertor stall ratio is 2.52:1

Manufacturer	JCB
Type	Synchroshuttle
Gears forward/reverse	4 forward/4 reverse
Shuttle control – F/R	Power shuttle
<b>Travel speeds*</b>	<b>mph (kph)</b>
Gear 1	3 (4.9)
Gear 2	5.3 (8.6)
Gear 3	12.3 (19.8)
Gear 4	22.8 (36.7)

\*Speeds may vary dependant on tire selection.

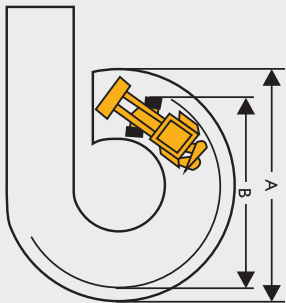
**TURNING CIRCLE**

\* Standard bucket in travel position

**Inner wheels braked**

A Outside loader bucket	9.50m
B Outside wheels	6.90m

**Inner wheels not braked**

A Outside loader bucket	10.40m
B Outside wheels	8.10m

**STEERING**

Front wheel full power hydrostatic system utilizing the main hydraulic pump via a steering priority valve. In the event of engine failure, emergency steering is maintained (all models).

**BRAKES**

**Service:** Hydraulically actuated dual line, self adjusting, oil immersed, multi-disc type on the rear axle, well protected from dirt, water etc. requiring no maintenance.

**Parking:** Hand operated, disc brake on rear axle input disc.

**Brake pedal:** Two independently operable foot pedals enable machine to maneuver in tight spaces. Pedals are linked together for normal use.

**HYDRAULIC SYSTEM**

• Main relief valve: 3,655 psi • Unloader valve: 3,002 psi • Pump type: 2 section displacement gear  
 • Pump capacity: 32.5g/min • Filtration through suction strainer and return line JCB Filtermatic filter  
 • During excavation the circuit automatically varies hydraulic power to match digging conditions for extra performance, control and power • Careful routing of hydraulic hoses and pipework guards against site damage and allows easy servicing

**CAB**

• Floor mats • Fully adjustable seat and soft touch steering wheel • 'Walk through' two door access  
 • Seat belt • Large convex rear view mirror • Interior light • Front screen wiper • Horn • Hazard warning system • Tool box • Instrumentation panel includes engine speed, engine hours, fuel level, water temperature gauge and 12v connection • Audible and visual fault warning system for alternator charge, coolant temperature, engine oil pressure, blocked air filter, transmission oil pressure and temperature, and hand brake on.

**AXLES**

**Rear:** Drive axle rigidly mounted, incorporates JCB Max-Trac torque proportioning differential, driven by short propshaft from gear box.

**Front:** 4WD, Steer axle, centrally pivoted with oscillation angle of 16°.

**ELECTRICAL AND INSTRUMENTATION**

12 volt negative ground, utilising wiring and connectors meeting IP69 water ingress test standard. Central fuse panel.

**Battery:** 110 A/hr **Alternator:** 95 amp standard.

**Rear working lights:** 2 fixed and 4 adjustable.

**Tires**

**Front:** Galaxy 14x17.5-10 (4WD)

**Rear:** Galaxy 19.5x24-12 (4WD)

**WEIGHT**

**Operating:** 17,196lb (7,800kg)

**BACKHOE LIFT CAPACITIES**

Excavator type		Standard	Extradig – Retracted	Extradig – Extended
<b>Boom lift capacity - SAE J31</b>				
+16	lb	-	-	1938
+14	lb	3386	3227	2117
+12	lb	3438	3266	2144
+10	lb	2550	2414	1631
+8	lb	2459	2320	1615
+6	lb	2363	2222	1589
+4	lb	2270	2127	1561
+2	lb	2184	2018	1534
Ground level	lb	2105	1957	1502
-2	lb	2034	1884	1476
-4	lb	1972	1819	1454
-6	lb	1923	1766	1440
-8	lb	1897	1735	1436
-10	lb	1948	1770	1453
-12	lb	-	-	1517
-14	lb	-	-	1801
<b>Dipper lift capacity - SAE J31</b>				
+16	lb	-	-	2065
+14	lb	3941	3856	2283
+12	lb	4334	4245	2382
+10	lb	3829	3763	2123
+8	lb	3884	3812	2161
+6	lb	4667	4582	2541
+4	lb	-	-	2653
+2	lb	-	-	2924
Ground level	lb	-	-	-

**LOADER ATTACHMENTS – 6 in I Bucket Fork Dimensions**

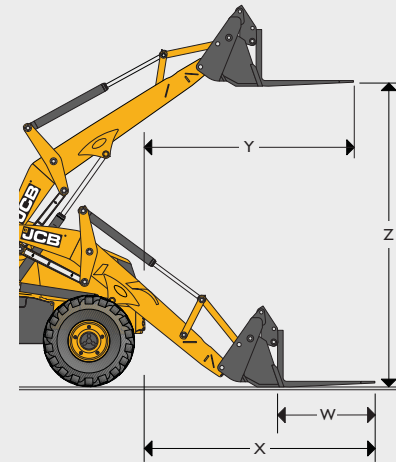

		6-in-1 bucket mounted forks
W	Forks – tine length	ft-in (m) 3-7 (1.1)
	Forks – tine length	ft-in (m) 0-3.1 (0.08)
X	Forks reach at ground level	ft-in (m) 8-9 (2.66)
Y	Forks reach at full height	ft-in (m) 7-5 (2.25)
Z	Forks lift height – max	ft-in (m) 9-7 (2.92)
	Fork spacing – min/max 10"	10" (260 mm) to 68" (1725 mm)

**LOADER ATTACHMENTS – Direct Mount**

HD bucket – 92", 1.3 yd <sup>3</sup>	lb (kg)	1697 (770)
6-in-1, 92" – with forks 1.3 yd <sup>3</sup>	lb (kg)	1940 (880)

**BACKHOE ATTACHMENTS – Buckets**

Bucket width	in (mm)	12 (305)	18 (455)	24 (610)	24 (610)	30 (760)	36 (910)
Number of teeth		3	4	4	5	5	6
<b>Heavy-duty trenching buckets</b>			18	24	24	30	36
Capacity	cu ft (cu m)	2.8 (0.08)	4.9 (0.14)	7.1 (0.20)	7.1 (0.20)	9.2 (0.26)	11.3 (0.32)
Weight	lb (kg)	293 (100)	359 (128)	408 (145)	419 (190)	478 (166)	544 (189)
<b>Heavy-duty high capacity trenching buckets</b>			4	4	5	5 (14.1)	6 (-)
Capacity	cu ft (cu m)	5.3 (0.15)	8.5 (0.24)	8.5 (0.24)	11.3 (0.32)	14.1	-
Weight	lb (kg)	430 (195)	509 (231)	514 (233)	588 (267)	668 (303)	-

See your JCB Dealer for availability of other backhoe buckets and attachments.

All JCB buckets include heavy-duty features consisting of a 1"x18" cutting edge, back straps, box section cross member, and full length, chamfered side cutters.

**BACKHOE ATTACHMENTS – Hydraulic Breakers**

Breaker model	mm	HM380	HM386Q
Operating weight	lb (kg)	727 (330)	794 (360)
Impact energy	ft/lb (joules)	723 (981)	443 (600)
Impact frequency	bpm	380-900	720-1380
Oil flow range	gpm (lpm)	9-17 (40-80)	16-26 (60-100)
Operating pressure	bar (psi)	1740-2393 (120-165)	100-150 (1450-2175)
Tool diameter	in (mm)	3 (75)	3.1 (80)

A wide variety of tools are available for JCB breakers. See your JCB Dealer for details.

**BACKHOE ATTACHMENTS – Patch Planer**

Cutting width	in (mm)	15.7 (400)
Cutting length	in (mm)	1.04-4.5 (1-115)
Weight	lb (kg)	1190 (540)
Hydraulic flow range	gpm (lpm)	24-53 (90-200)
Hydraulic pressure range	bar (psi)	140-210 (2030-3046)

**BACKHOE ATTACHMENTS – Compactor**

Weight	lb (kg)	395 (179)
Width	in (mm)	12 (305)
Length	in (mm)	29 (739)
Optimum machine down force	lb (kg)	1543 (700)
Centrifugal force	kN	16.3
Frequency	Hz	33
Oil flow	gpm (lpm)	6 (24)

**BACKHOE ATTACHMENTS – Auger\***

		ED3500	ED6000
Width	in (mm)	10.0 (254)	9.9 (253)
Length	in (mm)	23.2 (591)	24.1 (614)
Power head and hanger weight	lb (kg)	231 (105)	242 (110)
Oil flow @ 60rpm	gpm (lpm)	15.8 (60)	27.4 (104)
Oil flow min.	gpm (lpm)	30.4 (115)	30.4 (115)
Oil flow max.	gpm (lpm)	79.2 (300)	79.2 (300)

**BACKHOE ATTACHMENTS – Auger Flights\***

Weight	in (mm)	6 (150) - 18 (460)
Width	lb (kg)	42 (19) - 201 (91.2)
No. of teeth		2-16
Length	in (mm)	39.3(1000) - 47.2 (1200)

\*Available from September 2014