

Model R1932 SCISSOR LIFTS



MORE ECONOMIC

- Lower Total Cost of Ownership.

MORE PRODUCTIVE

- Boost efficiency with optional AGM batteries.
- Improved uptime.

MORE ACCESS

- Get into more places with compact dimensions and precise positioning ability for both drive and lift

SMART DESIGN

- Improved, reliable and simple active pothole protection.
- Platform and service trays are made of steel for more resistance.
- Wide-opening and stable steel doors provide easy access to batteries and components.

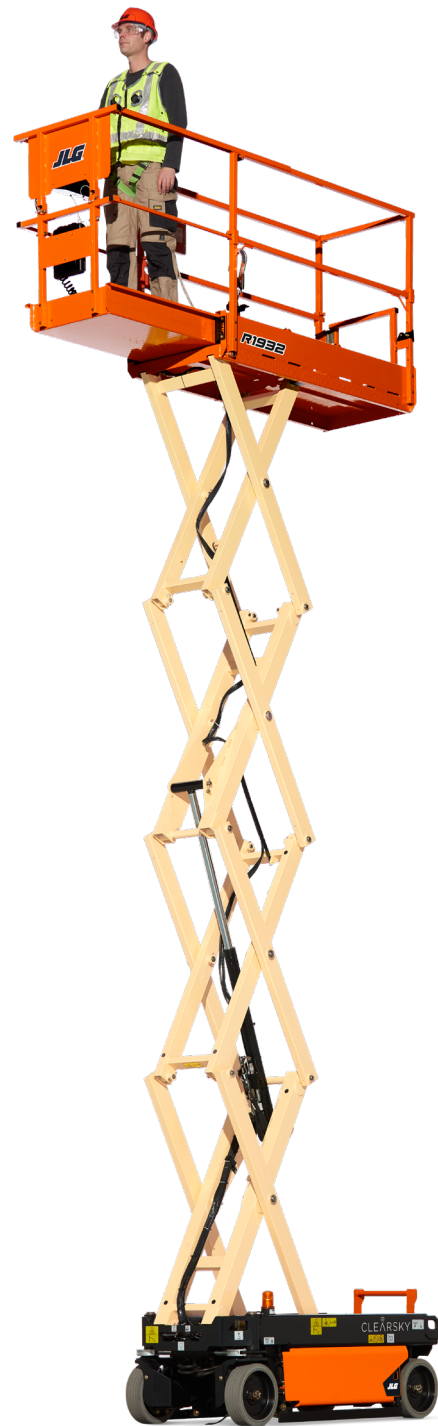

Standard Features

- 0.86 m roll-out deck extension
- Fold down handrails
- Half swing gate
- Removable platform control box
- Lanyard attach points
- Full proportional drive joystick control with integral thumb steer switch
- Proportional lift/lower speed control
- Joystick enable for lift and drive
- Zero load sensing system
- 4 x 6V 220 A/hr deep cycle batteries
- Automatic positive traction
- Programmable «Personality» settings
- On-board self-diagnostic testing
- Swingout steel battery/electrical compartments doors
- 27 amp automatic battery charger
- Front wheel hydraulic drive motors
- Dual wheel automatic brakes (on rear wheels)
- Emergency brake release
- Active pothole protection system
- AC cable to platform
- Battery charge level indicator
- Variable tilt indicator
- Hourmeter
- Lubrication free scissor arm bushings
- Scissor maintenance prop
- Manual descent
- Horn
- Non-marking solid tyres (323 x 100)
- Lifting and tie down points
- Slope alarm and light
- Fork lift pockets

Standard Specifications

- Drive Motors (Nominal) Hydraulic
- Batteries 4x 6V 220A/hr
- Charger (120/240V ~50/60Hz) 24v @27Amp Automatic
- Pump Motor 4.5kW
- Hydraulic System 18L
- Hydraulic Reservoir Pump Fixed displacement gear
- Tyres (Non-Marking Solid) 323 x 100 mm
- Brakes Hydraulic

Accessories & Options

- Narrow access rails
- Mobile control*
- 220A/hr maintenance free AGM batteries in lieu of standard
- All motion alarm
- Pipe racks
- Amber strobe light
- Anti-vandalism package
- Multi-display indicator (MDI)
- ClearSky Locate
- ClearSky CAN
- Drive motor covers
- Extension deployment handles
- Synthetic biodegradable hydraulic oil
- Hydraulic oil (Mobil 424)
- Panel carrier
- SkySense level 1
- Operator access control

* Pending CE certification

Model R1932

SCISSOR LIFTS

Performance

| | |
|---|----------------------|
| • Working Height | 7.80 m |
| • Platform Height - Elevated | 5.80 m |
| A. Stowed height | 2.02 m |
| B. Platform Height - Lowered | 0.98 m |
| C. Platform Railing Height | 1.15 m |
| D. Stowed Height (Rails Folded) | 1.76 m |
| E. Platform Size Inside (W x L) | 0.65 m x 1.57 m |
| F. Deck Extension | 0.86 m |
| G. Overall Width | 0.81 m |
| H. Overall Length ** | 1.74 m |
| I. Wheelbase | 1.35 m |
| J. Ground Clearance (centre of machine) | 7 cm |
| • Platform capacity – Indoor | 👤 /230 kg |
| • Platform capacity – Outdoor | 👤 /230 kg |
| • Capacity on Deck Extension | 120 kg |
| • Lift/Lower Time (no load) | 24/29 sec. |
| • Maximum Drive Height | 5.80 m |
| • Machine weight * | 1,565 kg |
| • Maximum Ground Bearing Pressure | 8 kg/cm ² |
| • Drive Speed - Lowered | 3.22 km/h |
| • Drive Speed - Elevated | 0.80 km/h |
| • Gradeability | 25% |
| • Turning Radius - Inside | 0.0 m |
| • Turning Radius - Outside | 1.69 m |



* Certain options or country standards may increase weight and/or dimensions.

** Incl ladder -7.4 cm, excl ladder 1.66 m

*** Outdoor measure, full height indoor

Dimensions

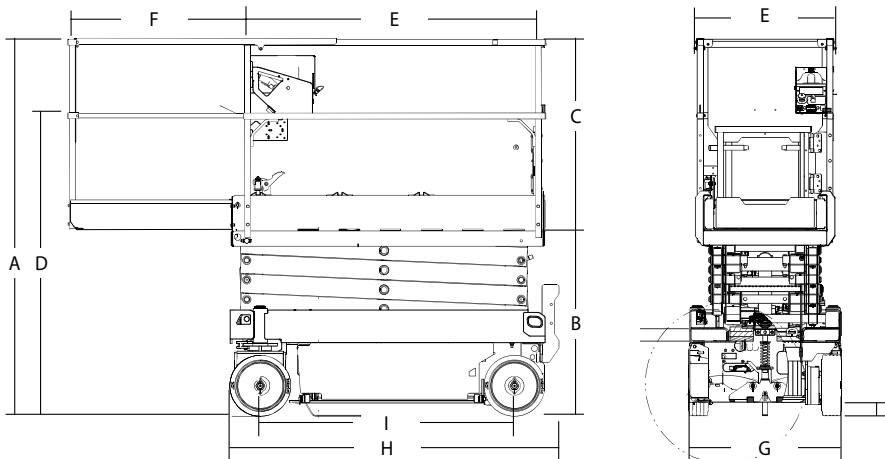

IMPORTANT

JLG is continually researching and developing products and reserves the right to make modifications without prior notice. All data in this document is indicative. Certain options or country standards will increase weight. Specifications may change to meet country standards or with the addition of optional equipment.

Due to continuous product improvements, JLG Industries reserves the right to make specification and/or equipment changes without prior notification.



JLG EMEA BV

Polaris Avenue 63
2132 JH Hoofddorp
The Netherlands
Phone: +31 (0)23 565 5665
www.jlg.com

An Oshkosh Corporation Company